

CERUS[™]
We Respond. 

P-SERIES BACnet Option Board



P-SERIES
BACnet Option Board

Thank you for purchasing BACnet Option Board.

SAFETY PRECAUTIONS

- Always follow safety instructions to prevent accidents and potential hazards from occurring.
- Safety precautions are classified into “WARNING” and “CAUTION” and their meanings are as follows:



WARNING

Improper operation may result in serious personal injury or death.



CAUTION

Improper operation may result in slight to medium personal injury or property damage.

- The indicated illustrations on the product and in the manual have the following meanings.



Danger may be present. Read the message and follow the instructions carefully.



Particular attention should be paid because danger of an electric shock may be present.

- Keep operating instructions handy for quick reference.
- Read the operating instructions carefully to fully understand the functions of the SV-iP5A series and to use it properly.



CAUTION

- **Be cautious, when handling the CMOS components of the Option Board.**
Static may lead to malfunctioning of the product.
- **Turn off the inverter power, when changing the communication cable.**
Otherwise, you may damage the board or a communication error may occur.
- **Make sure to insert the Option Board connector to the inverter precisely.**
Otherwise, you may damage the board or a communication error may occur.
- **Check the parameter unit before setting up the parameter.**
Otherwise, a communication error may occur.

Introduction

BACnet stands for “Building Automation and Control network.” It is a communication protocol, which is often used in the area of Building Automation.

BACnet adopted the “Object-Oriented” concept for the flexibility of the system. It defines the standardized object, and all the data is expressed using the property of this object. It exchanges data by using this object and makes it possible to communicate with the products of other manufacturers.

Furthermore, it standardizes those systems that operate by accessing to the defined objects.

1. BACnet Communication card Technical Data

Connection	Interface	5Pin Pluggable connector
	Data transmission method	RS-485 MS/TP, Half-duplex
	Cable	Twisted pair (1 pair and shield)
Communication	BACnet MS/TP	ANSI/ASHRAE Standards 135-2004
	Baud Rate	9600, 19200, 38400, 76800 bps
	MAC Address	1~127

BACnet Communication card Layout and Network connection

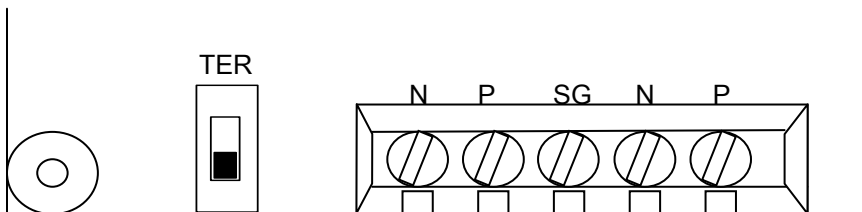
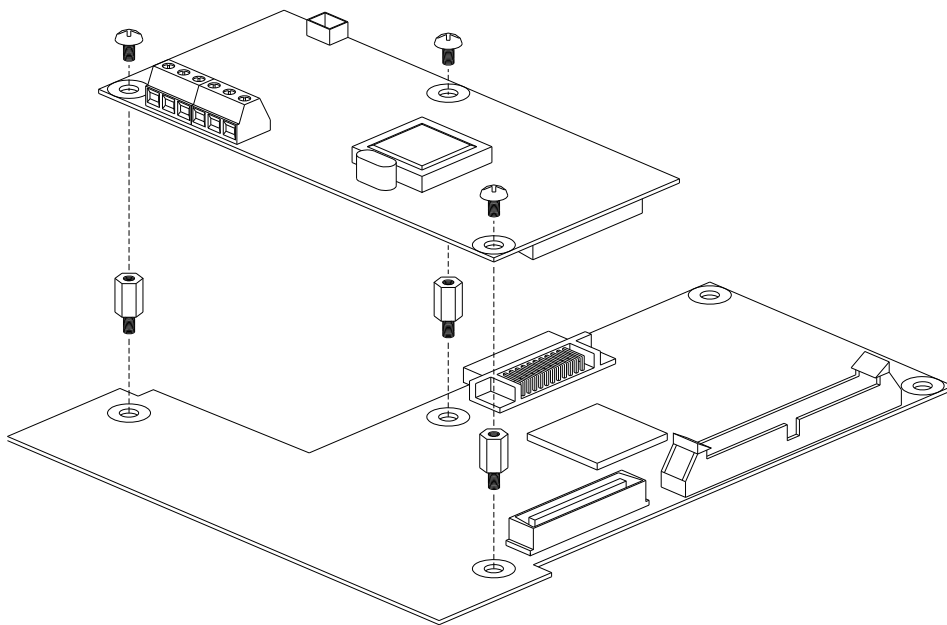

Signal	Description
TER	Termination Resistance Selection Switch (120 Ohm)

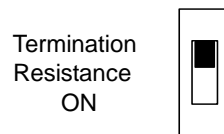
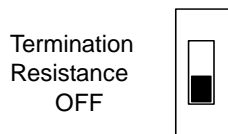

Signal	Connector Number	Description
N	1	Transmit/Receive data -
P	2	Transmit/Receive data +
SG	3	Signal Ground
N	4	Transmit/Receive data -
P	5	Transmit/Receive data +

※ Whether the right side 4 switches are On or Off, there is no effect to the BACnet communication card.

Hardware installation method

Warning! Connect to network after turning off the power of Inverter.

Use Belden 9842 or equivalent cable to it. Belden9842 is Dual Twisted Shielded pair cable, and its track impedance is 120 Ohm.

For communication, connect one out of 2 cables twisted to terminal N and the other one to terminal P.

Also, connect one out of the other 2 cables twisted to terminal SG, and the other is out of use.

Connect to network with Daisy-Chained Bus. (Not with Dropout Line)

To reduce noise, it is required to terminate register 120Ohm on Device of Networks' both ends. And, terminate, using terminal Dip switch on communication card.

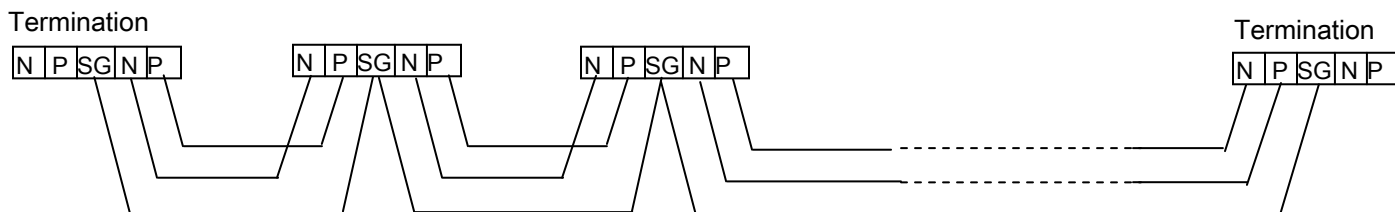

2. Status LED

There are 3 green LEDs and 1 red LED that indicate the present status of the BACnet Communication card and are lined up as follows on the BACnet Communication card.

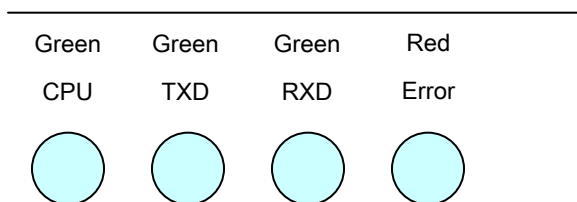

LED Name	Color	Status
CPU	Green	<p>Off – BACnet Communication card is getting no power supply or there is a problem with the card</p> <p>Blink – BACnet Communication card is getting power supply and it is at a normal state.</p>
ERROR	Red	<p>Blinks against the CPU cycle – Communication card is ready to communicate but not receiving or sending actual data.</p> <p>Blinks with the CPU cycle – There is a problem with the DPRam communication between the BACnet Communication card and inverter.</p> <p>Off – There is no error and BACnet Communication card is communicating.</p>
TXD	Green	<p>On – BACnet Communication card is sending communication frame.</p> <p>Off – BACnet Communication card is not sending data.</p>
RXD	Green	<p>ON – BACnet Communication card is receiving communication frame.</p> <p>Off – BACnet Communication card is not receiving data.</p>

When power is first supplied to the BACnet communication card and if it is not communicating, the TX LED lights up and RX LED remains off.

3. Quick Communication Start

1. Install the BACnet Communication card with the inverter power turned off. Make sure that the COM-01 parameter is "BACnet" after turning it on.
2. Connect to the network by connecting the cable with the BACnet Communication card.
3. Set IO-91 baud rate.
4. Set COM-63, 64 Device Object Instance.
 - ✓ The modified Device Instance value gets written in the Communication card only when the COM-67 Comm Update is set to "Yes" after setting COM-63, 64.
 - ✓ Set value to COM-63, COM-64. Device Object Instance must be a peculiar value.
5. Set MAC ID that is to be used in COM-61
 - ✓ When the COM-61 MAC ID value gets modified, it gets written in the Communication card only when the COM-67 Comm Update is set to "Yes"
 - ✓ To execute MS/TP token passing, the value of MAC ID has to be within the value limit that has been set by another Master's Max Master Property.
6. Check if BACnet communication is working properly.

4. BACnet related Keypad Parameter

Code	Parameter name	Default	Range	Description
IO-91	Baud rate	9600 bps	1200 bps 2400 bps 4800 bps 9600 bps 19200 bps 38400 bps 57600 bps 76800 bps 115200 bps	Set baud rate. From the range provided by IO-91, BACnet only supports 9600 bps, 19200 bps, 38400 bps, 76800 bps. When unsupported baud rate is set and COM-67 Comm Update is set to "Yes," the default of IO-91 automatically changes to 9600 bps.
COM-01	Opt B/D	-	-	Displays the Communication card installed on the inverter. (Displays RS485, when BACnet Communication card is installed)
COM-03	Opt Version	-	-	Displays version of the BACnet Communication card that has been installed on the inverter.
COM-61	Opt Para-1	1	1~127	MAC ID
COM-62	Opt Para-2	127	1~127	Max Master
COM-63	Opt Para-3	237	0~4194	BACnet Device Instance
COM-64	Opt Para-4	000	0~999	BACnet Device Instance
COM-65	Opt Para-5	0	0~32767	A password used on Warm/Cold Start.
COM-66	Opt Para-6	12345	-	-
COM-67	Comm Update	No	No Yes	In order to modify BACnet related parameters such as MAC ID, Baud Rate and Device Instance, the modified parameter value has to be set to "Yes."

(1) Baud rate (IO-91)

- ✓ Baud rate is the parameter for setting communication speed, which is to be used in the network and the default is 9600bps. If the user sets a baud rate that is not supported and sets the COM-67 Comm Update to "Yes," the IO-91 baud rate gets automatically set to default 9600bps and so does the BACnet Communication card.

(2) MAC ID (COM-61)

- ✓ Every MAC ID of the BACnet Communication card has to be set up before connecting to the Bus. Above all, the set up

value of the baud rate parameter has to match with the one of the Master Configuration.

- ✓ MAC ID needs its unique value in the network to be connected.
- ✓ Slave is used in 128~154 of the MAC ID and both Master, Slave is used in 1~127.
- ✓ BACnet communication card's MAC ID range is 1~127 because it is used for master. If you set MAC ID under 0 or over 127, and the COM-67 Comm Update as 'Yes' to apply the MAC ID to the BACnet communication card, then the COM-61 Opt Para-1 will be 1 which is the default value automatically.
- ✓ If you set the MAC ID more than the value of COM-62 Max Master, and the COM-67 Comm UpDate as 'Yes', then COM-61 MAC ID will be 1 which is the default value automatically.
- ✓ It is encouraged for the MS/TP router to use MAC ID value 0 and for the Broadcast 255.

(3) Max Master (COM-62)

- ✓ Max Master's range is 1~127, and the initial value is 127.
- ✓ If you set the Max Master over 128, and the COM-67 Comm Update as 'Yes' to apply the value, then the COM-62 Max Master's initial value will be 127 automatically.

(4) BACnet Device Instance (COM-63, COM-64)

- ✓ Because BACnet Device Instance is used to identify BACnet Device, it has to be set up with a unique value in the network. It is conveniently used, when searching for BACnet Device among other devices while installing.
- ✓ The value of (COM63 X 1000) + COM64 is applied for the Device Instance. In other words, COM-63 is the value over 1000 in the Device Instance and COM-64, under 100.
- ✓ Because the Device Instance has a value range of 0~4,194,302, COM-63 has a range of 0~5194 and COM-64, 0~999.
- ✓ If the user sets up a value bigger than 4,194,302 for COM-62 and COM-63, the Device Instance will automatically set up to the maximum value, which is 4,194,302.

(5) Password (COM-65)

- ✓ It is the password when you restart a machine with Warm/Cold Start. COM-65 Password's parameter is allowed to set 0~32767 and the initial value is 0. Warm/Cold Start operates with the parameter 1~32768 when both the password set on the BACnet Master and the COM-65 value are equal.
- ✓ If the COM-65 Password is 0, the password on the BACnet Master is ignored and the Warm/Cold Start is operated constantly.
- ✓ If you set the COM-65 Password over 32769, and the COM-67 Comm Update as 'Yes' to apply the value to the BACnet

communication card, then the COM-65 Password's initial value will be 0.

- ✓ There are three ways to apply the value of COM-65 Password to the communication card. The first is that you set the COM-67 Comm Update as 'Yes', the second is that you do the Warm/Cold Start operation, and the last is that you turn the power of the inverter off and on.

(6) Signature (COM-66)

- ✓ It is encouraged for the user not to use COM-66.

(7) Comm UpDate (COM-67)

- ✓ In order to modify and apply parameters which are related to the BACnet, such as MAC ID, Baud Rate, Delay Time, Device Instance, communication command loss time, communication command loss method, etc., you had better set the COM-67 Comm Update as 'Yes' to apply to the BACnet communication card.
- ✓ Communication card's LED goes on and off CPU→TXD→RXD→ERR in order.

※ Note)

There are three ways to apply the changed parameters to the BACnet communication card by a keypad.

- 1) Set the COM-67 Comm Update, keypad parameter, as 'Yes'.
- 2) Turn the power of the inverter off and on again.
- 3) Carry out the Cold Start or the Warm Start (ReinitializeDeiveControl). Both Cold Start and Warm Start are the same operation. After the Cold/Warm Start, the BACnet communication card's LED will go on and off CPU→TXD→RXD→ERR in order.

※ Note) Max Master and MAC ID have a big effect on the network communication.

You had better set the Max Master as small value as possible. MAC ID is better be set with continuous values. Each master wants to send a token to its device (MAC ID + 1). Therefore, you can operate an effective Token Passing Configuration, if you set the values of the Max Master and the MAC ID as has been mentioned above.

5. General Communication related Keypad Parameter

Code	Parameter Name	Default	Range	Description
DRV-91	Drive mode2	Fx/Rx-1	Keypad Fx/Rx-1 Fx/Rx-2	Multi-function input of IO-20~27 should be set as LOC / REM so that DRV-91, DRV-92 can be shown on Keypad.
DRV-92	Freq mode2	Keypad1	Keypad1 Keypad2 V1 V1S I V1+I Pulse	
IO-20~27	M1~M8 define	-	-	Related to communication when setting up Main-drive, one of multifunction's messages.
IO-92	Com Lost Cmd	None	None FreeRun Stop	Sets up mode for communication command loss.
IO-93	COM Time Out	1.0 sec	0.1~120.0 sec	Sets up time for communication command loss.
IO-94	Delay Time	5 ms	2~1000 ms	BACnet turnaround time. Set up IO-94 Delay Time correctly according to the setting value of IO-91 Baudrate. Recommendation is as follows. 9600 bps (range) = 5 ms, 19200 bps = 3 ms, 38400 bps = 2 ms, 76800 bps = 2 ms
COM-02	Opt mode	None	None Cmd Freq Cmd+Freq	Sets up mode. (Inverter operation, frequency command, both) Select 'Cmd+Freq' only to communicate with both inverter operation and frequency command.

6. Protocol Implement

(1) Service provided by BACnet Communication card

- ✓ I-Am (Answer to “Who-Is,” Broadcast after Power-up or when “Reset”)
- ✓ I-Have (Answer to “Who-Has”)
- ✓ ReadProperty
- ✓ WriteProperty
- ✓ DeviceCommunicationControl
 - Password is ignored on the DeviceCommunicationControl.

- ✓ ReinitializeDevice
 - Warm/Cold Start is supported(Password is supported)
During the operation of Warm/Cold Start, Communication card’s LED goes on and off CPU→TXD→RXD→ERR in order.
 - Start Backup, End Backup, Start Restore, End Restore, and Abort Restore are not supported.

(2) Data Link Layer

- ✓ BACnet Communication card puts through MS/TP Master Data Link Layer. All standard MS/TP provides 9600, 19200, 38400, 76800 bps.

(3) MAC ID/Device Object Instance

- ✓ Set COM-61 MAC ID
- ✓ Set Device Object Instance from COM-63, COM-64

(4) Max Master Property

- ✓ It is possible to configure Device Object Max Master Property by setting up the value of COM-62 Max Master

7. Object Map

Property	Object Type						
	Device	BI	BV	AI	AO	MSI	MVI
Object Identifier	○	○	○	○	○	○	○
Object Name	○	○	○	○	○	○	○
Object Type	○	○	○	○	○	○	○
System Status	○						
Vendor Name	○						
Vendor Identifier	○						
Model Name	○						
Firmware Revision	○						
Apply Software Revision	○						
Location	○						
Protocol Version	○						
Protocol Revision	○						
Services Supported	○						
Object Types Supported	○						
Object List							
Max APDU Length	○						
UTC Offset	○						
Daylight Savings Status	○						
APDU Timeout	○						
Number APDU Retries	○						
Time Synchronizations Recipients	○						
Max Master	○						
Max Info Frames	○						
Device Address Binding	○						
Database Revision	○						
Present Value		○	○	○	○	○	○
Description	○	○	○	○	○	○	○
Status Flags		○	○	○	○	○	○
Event State		○	○	○	○	○	○
Reliability		○	○	○	○	○	○
Out-of-Service		○	○	○	○	○	○
Number of states						○	○
State text						○	○
Units				○	○		
Polarity		○					
Active Text		○	○				
Inactive Text		○	○				

- BI – Binary Input
- BV – Binary Value
- AI – Analog Input
- AV – Analog Value
- MSI – Multi-state Input
- MSV – Multi-state Value

Location and Description(Device Object) is available for Read/Write access. Maximum number of character of these is 29 characters

7.1 Analog Value Object Instance

Instance ID	Object Name	Description	Range	Units	Present Value Access Type
AV1	CommTimeout	Lost Communication Timeout	0.1 ~ 120.0	Secs.	R / W
AV2	AccelTime	Acceleration Time	0.0 ~ 600.0	Secs.	R / W
AV3	DecelTime	Deceleration Time	0.0 ~ 600.0	Secs.	R / W
AV4	CommandFreq	Command Frequency	0.00 ~ FU1-30	Hz	R / W

Data Type is Real when "Write."

※ Note) AV4 is able to be set within the value of the FU1-30 Max Freq. FU1-30 is allowed to input 0.00~120.00.

7.2 Multi-state Value Object Instance

Instance ID	Object Name	Description	-	Present Value Access Type
MSV1	LostCommand	Lost Communication Behavior	1 None 2 FreeRun 3 Stop	R / W
MSV2	OperateMode	Operating Mode	1 None 2 Cmd 3 Freq 4 Cmd+Freq	R / W
MSV3	DriveMode	Drive Mode2 Note1)	1 Keypad 2 FX/RX-1 3 FX/RX-2	R / W
MSV4	FreqMode	Frequency Mode2 Note1)	1 Keypad1 2 Keypad2 3 V1 4 V1S 5 I 6 V1+I 7 Pulse	R / W

Note1) In order to see Drive Mode2, Freq Mode2 on the Keypad, IO-20~27 M1~M8 define has to be set as LOC/REM

Data Type is Unsigned when "Write."

7.3 Binary Value Object Instance

Instance ID	Object Name	Description	Active / Inactive Text	Present Value Access Type
BV1	Stop	Binary Output Stop command	False/True	R / W
BV2	RunForward	Binary Output Run Forward command	False/True	R / W
BV3	RunReverse	Binary Output Run Reverse command	False/True	R / W
BV4	ResetFault	Reset Fault	False/True	R / W
BV5	EmergencyStop	Binary Output Emergency Stop command	False/True	R / W

Data Type is Enumerated when "Write."

※ Note) False means 0, and True means 1.

7.4 Analog Input Object Instance

Instance ID	Object Name	Description	Units	Present Value Access Type
AI1	InvCap	Inverter Capacity	kW	R
AI2	InvInputVoltage	Inverter Input Voltage	Volts	R
AI3	OutputCurrent	Output Current	Amps	R
AI4	OutputFreq	Output Frequency	Hz	R
AI5	OutputVoltage	Output Voltage	Volts	R
AI6	DCLinkVoltage	DC Link Voltage	Volts	R
AI7	OutputPower	Output Power	kW	R
AI8	V1	V1	Volts	R
AI9	V2	V2	Volts	R
AI10	I	Current	mA	R
AI11	Speed	Drive Speed	RPM	R
AI12	Pole	Pole Number	-	R
AI13	TripInfo	Composite Trip Information	Note3)	R
AI14	InvStatus	Composite Inverter Status	Note4)	R

Note) AI8, AI9, and AI10 values are read related to voltage(0~15V) and current(0~22mA) in a linear form from 0~ to FFF

Note3) 16Bit Trip BIT Information

BIT0	OCT1
BIT1	OV
BIT2	EXT-A
BIT3	BX
BIT4	LV
BIT5	RESERVE
BIT6	GF (Ground Fault)
BIT7	OHT (Inverter overheat)
BIT8	ETH (Motor overheat)
BIT9	OLT (Overload trip)
BIT10	HW-Diag
BIT11	RESERVE
BIT12	OCT2
BIT13	OPT (Option Error)
BIT14	PO (Phase Open)
BIT15	IOLT

Note4) Inverter Status BIT Information

BIT0	Stop
BIT1	Forward running
BIT2	Reverse running
BIT3	Trip
BIT4	Accelerating
BIT5	Decelerating
BIT6	Speed arrival
BIT7	DC Braking
BIT8	Stopping
BIT9	Not used
BIT10	Brake Open
BIT11	Forward run command
BIT12	Reverse run command
BIT13	REM R/S (Int 485, Opt)
BIT14	REM Freq (Int 485, Opt)
BIT15	Not used

7.5 Binary Input Object Instance

Instance ID	Object Name	Description	-	Present Value Access Type
BI1	Stopped	Inverter is Stopped	-	R
BI2	RunningForward	Inverter is running forward	-	R
BI3	RunningReverse	Inverter is running reverse	-	R
BI4	Tripped	Inverter is Tripped	-	R
BI5	Accelerating	Inverter is Accelerating	-	R
BI6	Decelerating	Inverter is Decelerating	-	R
BI7	FullSpeed	Inverter reached full speed	-	R
BI8	DCBraking	Inverter is DC braking	-	R
BI9	Stopping	Inverter is stopping	-	R
BI10	BrakeOpen	Inverter Brake is Open	-	R
BI11	FwdRunCommand	Inverter Forward Run Command	-	R
BI12	RevRunCommand	Inverter Reverse Run Command	-	R
BI13	REMRS	REM. R/S Int 485 OPT	-	R
BI14	REMFreq	REM. Freq Int 485 OPT	-	R
BI15	M1	M1 Input Terminal	-	R
BI16	M2	M2 Input Terminal	-	R
BI17	M3	M3 Input Terminal	-	R
BI18	M4	M4 Input Terminal	-	R
BI19	M5	M5 Input Terminal	-	R
BI20	M6	M6 Input Terminal	-	R
BI21	M7	M7 Input Terminal	-	R
BI22	M8	M8 Input Terminal	-	R
BI23	AUX1	AUX1 Output Terminal Status	-	R
BI24	AUX2	AUX2 Output Terminal Status	-	R
BI25	AUX3	AUX3 Output Terminal Status	-	R
BI26	AUX4	AUX4 Output Terminal Status	-	R
BI27	Q1	Q1 (OC1) Output Terminal Status	-	R
BI28	Q2	Q2 (OC2) Output Terminal Status	-	R
BI29	Q3	Q3 (OC3) Output Terminal Status	-	R
BI30	30AC	30AC Output Terminal Status	-	R

7.6 Multi-state Input Object Instance

Instance ID	Object Name	Description	-	Present Value Access Type
MSI1	UnitsDisplay	Engineering Units on Display	1 Hz 2 RPM	R

8. Error message

Display	Description
serviceserror+7	Inconsistent parameters
propertyerror+9	Invalid Data Type
serviceserror+10	Invalid access method
serviceserror+11	Invalid file start
serviceserror+29	Service request denied
objecterror+31	Unknown object
propertyerror+0	Property other
propertyerror+27	Read access denied
propertyerror+32	Unknown property
propertyerror+37	Value out of range
propertyerror+40	Write access denied
propertyerror+42	Invalid array index
clienterror+31	Unknown device
resourceserror+0	Resources other
clienterror+30	Time out
abortreason+4	Segmentation not supported
rejectreason+4	Invalid tag
clienterror+0xFF	No invoke id
securityerror+26	Password failure